

VOLTAGE QUADRUPLER USING TD310

by R. LIOU

INTRODUCTION

The TD310 is a triple MOS or IGBT driver which integrates all functions suited for compact and highly secure driving such as adjustable Under Voltage Lockout feature (UVLO), sense comparator with alarm output and automatic shutdown, independent operational amplifier, enable pin, and global standby mode (e.g.: for portable applications).

The following describes how to generate a DC voltage 4 times higher than the supply voltage of the TD310. This voltage may be used as a 2.5W/60V DC supply.

PRINCIPLE

Please refer to Figure 1.

The buffer n°1 is used as an oscillator. The total swing of the oscillation is shifted of +Vcc due to the couple diode-capacitor D1,C1 (the real signal shift is +Vcc-0.6V due to the diode voltage drop). The couples D2,C2 and D3,C3 also shift this signal of +Vcc each. Due to the inverting function of each buffer, the maximum swing is applied at each oscillation cycle across each capacitor, ensuring maximum efficiency. The couple D4,C4, where C4 is a tank capacitor smooths the DC voltage which reaches approximately 4 times Vcc.

Figure 1 shows the voltage quadrupler application schematic, and Figure 2 shows the resulting traces when Vcc=15V:

- trace 1 : buffer n°1 output (oscillator)
- trace 2 : tank capacitor C4 output (DC voltage)

Figure 1

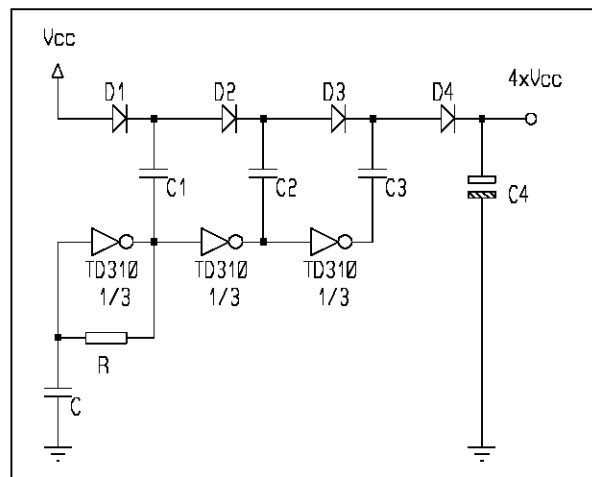
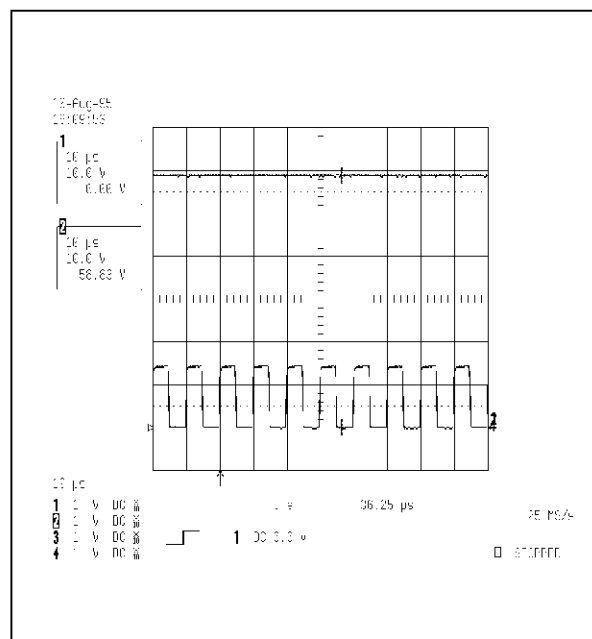

Figure 2



APPLICATION NOTE

DESIGN CONSIDERATIONS

To each triplet of capacitors C1, C2, C3 corresponds an optimal frequency of oscillation of the buffer 1.

The traces shown on Figure 2 have been realised with C1=C2=C3=1µF, at Vcc=15V and 100kHz.

Best efficiency is obtained with 50% oscillator duty cycle

The voltage across the tank capacitor C4 cannot exceed 4xVcc - 4xVd (diode voltage drop)

Figure 3 shows the voltage drop across the tank capacitor C4 (10µF) when a 1kW load is connected. The power dissipated in the load is:

$$\blacksquare U2/R = 522/103 = 2.7W$$

NOTES

As the TD310 can be supplied under a very wide supply voltage range, a 20V supply is achievable from a 5V supply.

The enable pin and standby mode are still available, as well as a comparator and an operational amplifier (eg: post regulation).

The same principle, using only two inverters can be used to make an NxVcc DC voltage supply.

Figure 3

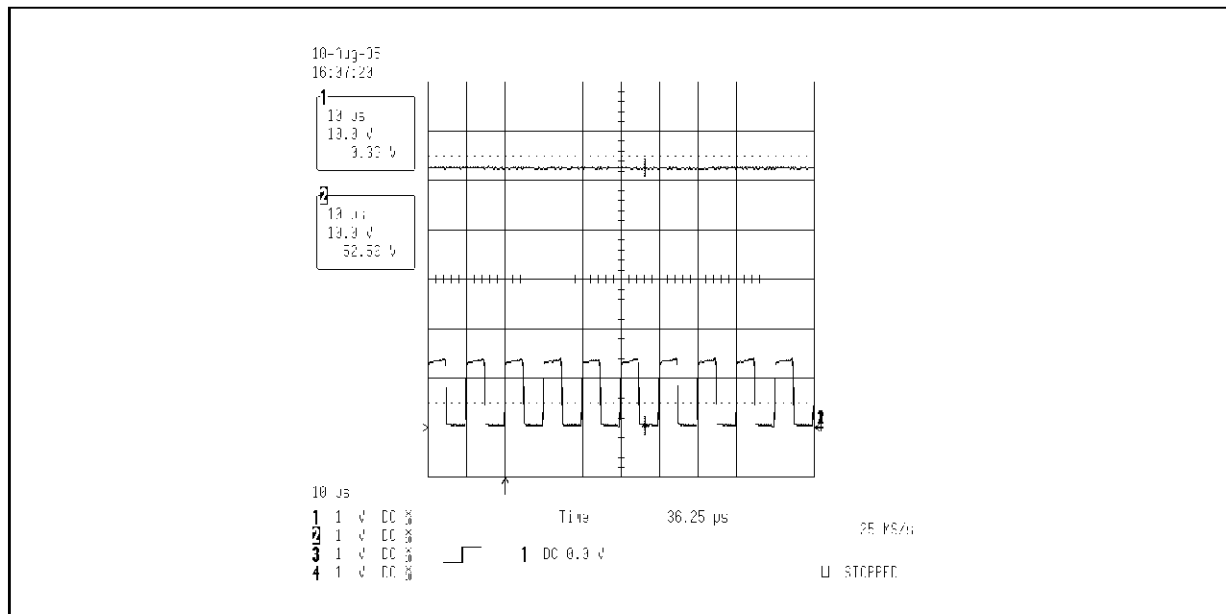

Information furnished is believed to be accurate and reliable. However, SGS-THOMSON Microelectronics assumes no responsibility for the consequences of use of such information nor for any infringement of patents or other rights of third parties which may result from its use. No licence is granted by implication or otherwise under any patent or patent rights of SGS-THOMSON Microelectronics. Specifications mentioned in this publication are subject to change without notice. This publication supersedes and replaces all information previously supplied. SGS-THOMSON Microelectronics products are not authorized for use as critical components in life support devices or systems without express written approval of SGS-THOMSON Microelectronics.

© 1996 SGS-THOMSON Microelectronics - All Rights Reserved

SGS-THOMSON Microelectronics GROUP OF COMPANIES

Australia - Brazil - France - Germany - Hong Kong - Italy - Japan - Korea - Malaysia - Malta - Morocco - The Netherlands
Singapore - Spain - Sweden - Switzerland - Taiwan - Thailand - United Kingdom - U.S.A.

ORDER CODE: